

## +5.0V, ±15kV ESD-Protected, Fail-Safe, Hot-Swap, RS-485/RS-422 Transceivers

### ■ Description

The TK13084E +5.0V, ±15kV ESD-protect-ed, RS-485/RS-422 transceivers feature one driver and one receiver. These devices include fail-safe circuitry, guaranteeing a logic-high receiver output when receiver inputs are open or shorted. The receiver outputs a logic-high if all transmitters on a terminated bus are disabled (high impedance). The TK13084E family include a hot-swap capability to eliminate false transitions on the bus during power-up or hot insertion.

The TK13084E feature reduced slew-rate drivers that minimize EMI and reduce reflections caused by improperly terminated cables, feature slew-rate-limited drivers but allow transmit speeds up to 500kbps.It is intended for full-duplex communica-tions.

All devices have a 1/8-unit load receiver input impedance, allowing up to 256 trans-ceivers on the bus.It is available in 8-pin SOIC packages.The devices operate over the commercial, extended, and automotive temperature ranges.

### ■ Features

- 1 transmitter and 1 receivers of the serial data of the standard RS-485
- Free Data Transmission,Allow Up to 256 Transceivers on the Bus
- Supply voltage range: 5.0V ± 5%
- Operating temperature range: -40 ~ +85 °C
- ESD protection up to 2000V for transmitter input and receiver output (TTL/CMOS levels) and up to 15000V for transmitter output and receiver input (RS-485 levels)
- Enhanced ESD Specifications:
  - ±15kV IEC61000-4-2 Air Discharge
  - ±8kV IEC61000-4-2 Contact Discharge

### ■ Ordering Information

Part Number	Package	Packing	Temperature(TA)	Package Qty	ESD
TK13084ECSA	SOIC-8	Reel	0°C ~ 70°C	2500	±15KV
TK13084EESA	SOIC-8	Reel	-40°C ~ 85°C	2500	±15KV

Note: Please contact us to customize DIP packaging device.

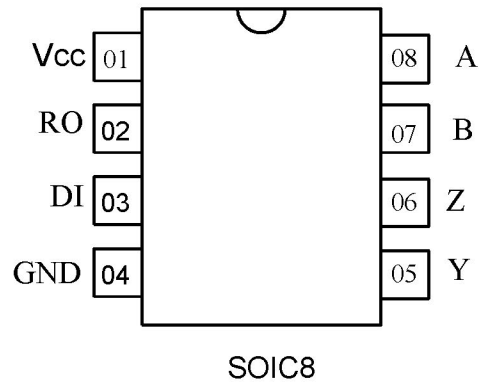
**Pin Description**

**Table 1. Pin Description**

Pin Number	Symbol	Pin Description
01	Vcc	Positive Supply $V_{CC} = +5.0V \pm 10\%$ . Bypass $V_{CC}$ to GND with a $0.1\mu F$ capacitor.
02	RO	Receiver Output. When $\overline{RE}$ is low and if $(A - B) \geq -50mV$ , RO is high; if $(A - B) \leq -200mV$ , RO is low.
03	DI	Driver Input. With DE high, a low on DI forces noninverting output low and inverting output high. Similarly, a high on DI forces noninverting output high and inverting output low.
04	GND	Ground
05	Y	Noninverting Driver Output
06	Z	Inverting Driver Output
07	B	Inverting Receiver Input
08	A	Noninverting Receiver Input

**Table 2. Transmitter Truth Table**

TRANSMITTING		
INPUT	OUTPUTS	
DI	Z	Y
H	L	H
L	H	L

Note : H – high level, L – low level

**Table 3. Receiver Truth Table**

RECEIVING	
INPUTS	OUTPUT
A, B	RO
$\geq -50\text{mV}$	H
$\leq -200\text{mV}$	L
Open/shorted	H

Note : H – high level, L – low level

**Table 4. Recommended Operating Condition**

Symbol	Parameter	Limit		Unit
		min	max	
$V_{CC}$	Supply voltage	4.75	5.25	V
$V_{IL}$	Input low voltage DI, DE, $\overline{RE}$ pins	0	0.8	V
$V_{IH}$	Input high voltage DI, DE, $\overline{RE}$ pins	2.0	$V_{CC}$	V
$V_{OD}$	Transmitter output voltage	-7.0	12.0	V
$V_{IR}$	Receiver input voltage	-7.0	12.0	V
$V_{OR}$	Receiver output voltage	0	$V_{CC}$	V
$V_{TH}$	Receiver differential threshold voltage	$ \pm 50 $	$ \pm 200 $	V
T	Ambient temperature	-40	85	°C

**Table 5. Maximum Ratings**

Symbol	Parameter	Limit		Unit
		min	max	
$V_{CC}$	Supply voltage	-	7.0	V
$V_{IL}$	Input voltage on pins DI, DE, $\overline{RE}$	-0.3	7.0	V
$V_{OD}$	Transmitter output voltage	-13	13	V
$V_{IR}$	Receiver input voltage	-13	13	V
$V_{OR}$	Receiver output voltage	-0.3	$V_{CC}+0.3$	V

\* Stresses beyond those listed under “maximum ratings” may cause permanent damage to the device. These are stress ratings only and functional operation of the device at these or any other conditions beyond those indicated under “recommended operating conditions” is not implied. Exposure to absolute-maximum-rated conditions for extended periods may affect device reliability.

**Table 6. Electrical Parameters**

 (V<sub>CC</sub> = 5V ± 5%)

PARAMETER	SYMBOL	CONDITIONS	MIN	TYP	MAX	UNITS	
<b>DRIVER</b>							
V <sub>CC</sub> Supply-Voltage Range	V <sub>CC</sub>		4.5		5.5	V	
Differential Driver Output	V <sub>OD</sub>	R <sub>L</sub> = 100Ω (RS-422), Figure 1	3		V <sub>CC</sub>	V	
		R <sub>L</sub> = 54Ω (RS-485), Figure 1	2		V <sub>CC</sub>		
		No load			V <sub>CC</sub>		
Change in Magnitude of Differential Output Voltage	ΔV <sub>OD</sub>	R <sub>L</sub> = 100Ω or 54Ω, Figure 1 (Note 2)			0.2	V	
Driver Common-Mode Output Voltage	V <sub>OC</sub>	R <sub>L</sub> = 100Ω or 54Ω, Figure 1		V <sub>CC</sub> / 2	3	V	
Change in Magnitude of Common-Mode Voltage	ΔV <sub>OC</sub>	R <sub>L</sub> = 100Ω or 54Ω, Figure 1 (Note 2)			0.2	V	
Input-High Voltage	V <sub>IH</sub>	DE, DI, $\overline{RE}$ , TXP, RXP, H/ $\overline{F}$	3			V	
Input-Low Voltage	V <sub>IL</sub>	DE, DI, $\overline{RE}$ , TXP, RXP, H/ $\overline{F}$			0.8	V	
Input Hysteresis	V <sub>HYS</sub>	DE, DI, $\overline{RE}$ , TXP, RXP, H/ $\overline{F}$		100		mV	
Input Current	I <sub>IN1</sub>	DE, DI, $\overline{RE}$			±1	μA	
Input Impedance First Transition		DE	1		10	kΩ	
Input Current	I <sub>IN2</sub>	TXP, RXP, H/ $\overline{F}$ internal pulldown	10		40	μA	
SRL Input-High Voltage			V <sub>CC</sub> - 0.4			V	
SRL Input-Middle Voltage			V <sub>CC</sub> x 0.3		V <sub>CC</sub> x 0.7	V	
SRL Input-Low Voltage					0.4	V	
SRL Input Current		SRL = V <sub>CC</sub>			75	μA	
		SRL = GND	-75				
Output Leakage (Y and Z) Full Duplex	I <sub>O</sub>	DE = GND, V <sub>CC</sub> = GND or V <sub>CC</sub>	V <sub>IN</sub> = +12V		125	μA	
			V <sub>IN</sub> = -7V	-100			
Driver Short-Circuit Output Current	I <sub>OSD</sub>	0 ≤ V <sub>OUT</sub> ≤ +12V (Note 3)			40	250	mA
					-250	-40	
			0 ≤ V <sub>OUT</sub> ≤ +12V, +85°C ≤ T <sub>A</sub> ≤ +125°C (Note 3)		40	270	
			-7V ≤ V <sub>OUT</sub> ≤ V <sub>CC</sub> , +85°C ≤ T <sub>A</sub> ≤ +125°C (Note 3)		-270	-40	
Driver Short-Circuit Foldback Output Current	I <sub>OSDF</sub>	(V <sub>CC</sub> - 1V) ≤ V <sub>OUT</sub> ≤ +12V (Note 3)		20		mA	
		-7V ≤ V <sub>OUT</sub> ≤ +1V (Note 3)			-20		
Thermal-Shutdown Threshold	T <sub>TS</sub>			175		°C	
Thermal-Shutdown Hysteresis	T <sub>TSH</sub>			15		°C	
Input Current (A and B)	I <sub>A, B</sub>	DE = GND, V <sub>CC</sub> = GND or V <sub>CC</sub>	V <sub>N</sub> = +12V		125	μA	
			V <sub>N</sub> = -7V	-100			
<b>RECEIVER</b>							
Receiver Differential Threshold Voltage	V <sub>TH</sub>	-7V ≤ V <sub>CM</sub> ≤ +12V	-200	-125	-50	mV	
Receiver Input Hysteresis	ΔV <sub>TH</sub>	V <sub>A</sub> + V <sub>B</sub> = 0V		15		mV	
RO Output-High Voltage	V <sub>OH</sub>	I <sub>O</sub> = -1mA	V <sub>CC</sub> - 0.6			V	
RO Output-Low Voltage	V <sub>OL</sub>	I <sub>O</sub> = 1mA			0.4	V	
Three-State Output Current at Receiver	I <sub>OZR</sub>	0 ≤ V <sub>O</sub> ≤ V <sub>CC</sub>			±1	μA	
Receiver Input Resistance	R <sub>IN</sub>	-7V ≤ V <sub>CM</sub> ≤ +12V	96			kΩ	
Receiver Output Short-Circuit Current	I <sub>OSR</sub>	0V ≤ V <sub>RO</sub> ≤ V <sub>CC</sub>			±110	mA	

**Table 6. Electrical Parameters (continued)**

PARAMETER	SYMBOL	CONDITIONS	MIN	TYP	MAX	UNITS
<b>SUPPLY CURRENT</b>						
Supply Current	I <sub>CC</sub>	No load, $\overline{RE} = 0$ , DE = V <sub>CC</sub>		1.2	1.8	mA
		No load, $\overline{RE} = V_{CC}$ , DE = V <sub>CC</sub>		1.2	1.8	
		No load, $\overline{RE} = 0$ , DE = 0		1.2	1.8	
Supply Current in Shutdown Mode	I <sub>SHDN</sub>	$\overline{RE} = V_{CC}$ , DE = GND		2.8	10	μA
<b>ESD PROTECTION</b>						
ESD Protection for Y, Z, A, and B		Human Body Model		±15		kV
		Contact Discharge IEC 61000-4-2		±6		kV

### DRIVER SWITCHING CHARACTERISTICS

(V<sub>CC</sub> = +5.0V ±10%, T<sub>A</sub> = T<sub>MIN</sub> to T<sub>MAX</sub>, unless otherwise noted. Typical values are at V<sub>CC</sub> = +5.0V and T<sub>A</sub> = +25°C.)

PARAMETER	SYMBOL	CONDITIONS	MIN	TYP	MAX	UNITS
Driver Propagation Delay	t <sub>DPLH</sub>	C <sub>L</sub> = 50pF, R <sub>L</sub> = 54Ω, Figures 2 and 3	200		1000	ns
	t <sub>DPHL</sub>					
Driver Differential Output Rise or Fall Time	t <sub>R</sub> , t <sub>F</sub>	C <sub>L</sub> = 50pF, R <sub>L</sub> = 54Ω, Figures 2 and 3	250		900	ns
Differential Driver Output Skew  t <sub>DPLH</sub> - t <sub>DPHL</sub>	t <sub>DSKEW</sub>	C <sub>L</sub> = 50pF, R <sub>L</sub> = 54Ω, Figures 2 and 3			140	ns
Maximum Data Rate			500			kbps
Driver Enable to Output High	t <sub>DZH</sub>	Figure 4			2500	ns
Driver Enable to Output Low	t <sub>DZL</sub>	Figure 5			2500	ns
Driver Disable Time from Low	t <sub>DLZ</sub>	Figure 5			100	ns
Driver Disable Time from High	t <sub>DHZ</sub>	Figure 4			100	ns
Driver Enable from Shutdown to Output High	t <sub>DZH(SHDN)</sub>	Figure 4			5500	ns
Driver Enable from Shutdown to Output Low	t <sub>DZL(SHDN)</sub>	Figure 5			5500	ns
Time to Shutdown	t <sub>SHDN</sub>		50	340	700	ns

### RECEIVER SWITCHING CHARACTERISTICS

(V<sub>CC</sub> = +5.0V ±10%, T<sub>A</sub> = T<sub>MIN</sub> to T<sub>MAX</sub>, unless otherwise noted. Typical values are at V<sub>CC</sub> = +5.0V and T<sub>A</sub> = +25°C.)

PARAMETER	SYMBOL	CONDITIONS	MIN	TYP	MAX	UNITS
Receiver Propagation Delay	t <sub>RPLH</sub>	C <sub>L</sub> = 15pF, Figures 6 and 7			200	ns
	t <sub>RPHL</sub>					
Receiver Output Skew  t <sub>RPLH</sub> - t <sub>RPHL</sub>	t <sub>RSKEW</sub>	C <sub>L</sub> = 15pF, Figures 6 and 7			30	ns
Maximum Data Rate			500			kbps
Receiver Enable to Output Low	t <sub>RZL</sub>	Figure 8			50	ns
Receiver Enable to Output High	t <sub>RZH</sub>	Figure 8			50	ns
Receiver Disable Time from Low	t <sub>RLZ</sub>	Figure 8			50	ns
Receiver Disable Time from High	t <sub>RHZ</sub>	Figure 8			50	ns
Receiver Enable from Shutdown to Output High	t <sub>RZH(SHDN)</sub>	Figure 8			5500	ns
Receiver Enable from Shutdown to Output Low	t <sub>RZL(SHDN)</sub>	Figure 8			5500	ns
Time to Shutdown	t <sub>SHDN</sub>		50	340	700	ns

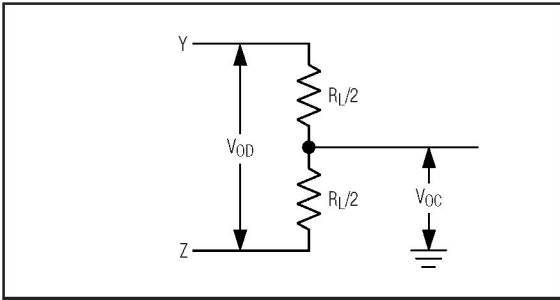

Figure 1. Driver DC Test Load

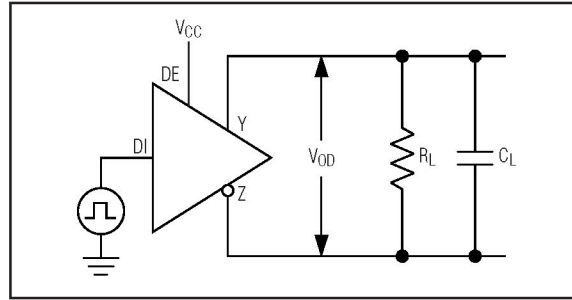

Figure 2. Driver Timing Test Circuit

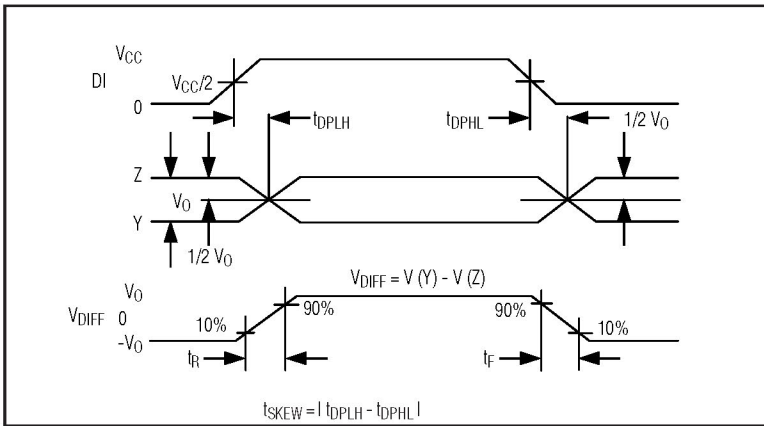

Figure 3. Driver Propagation Delays

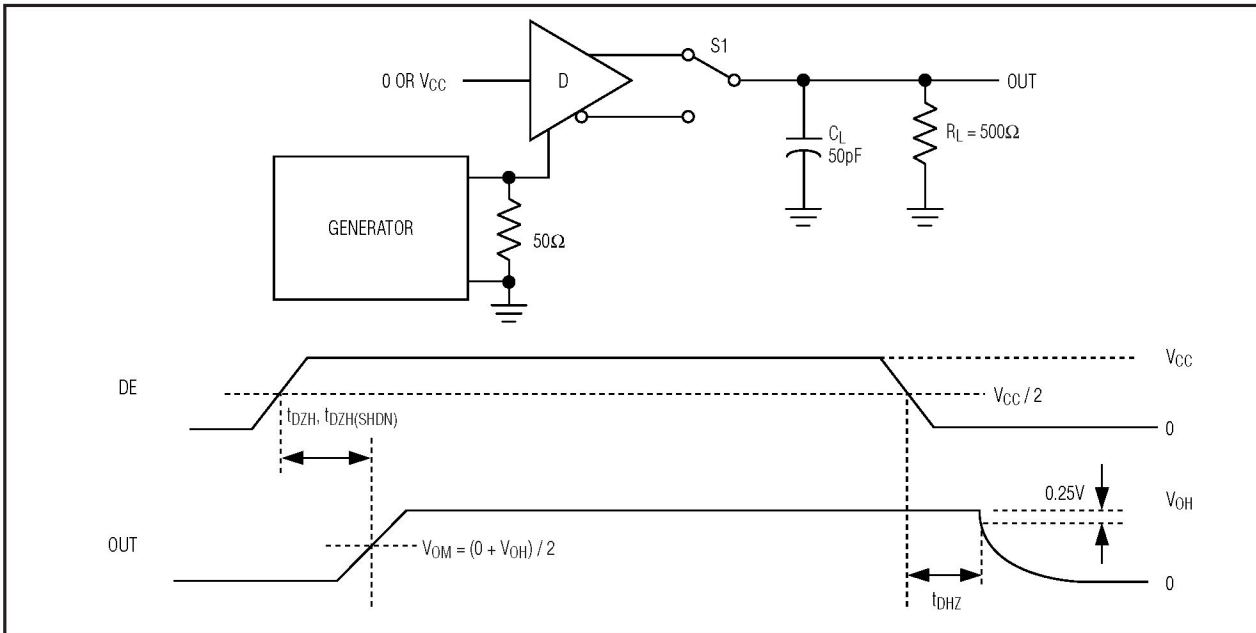

Figure 4. Driver Enable and Disable Times ( $t_{DZH}$ ,  $t_{DZH(SHDN)}$ ,  $t_{DHZ}$ )

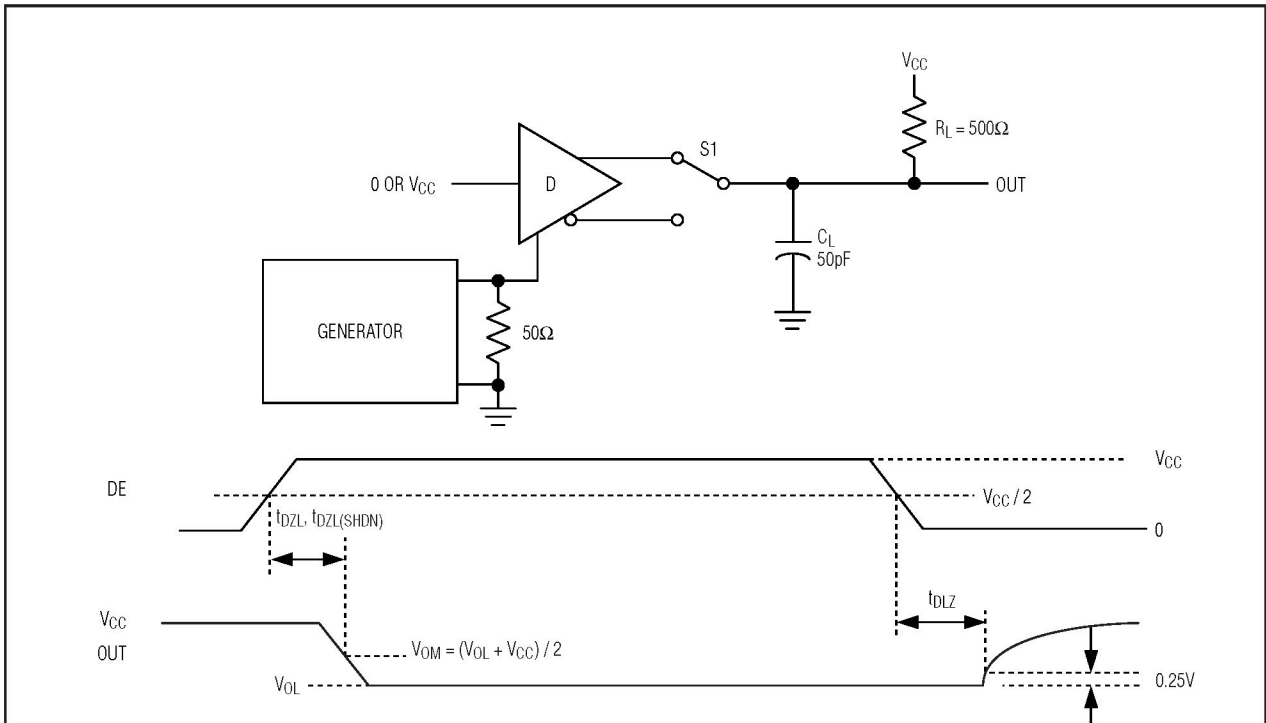

Figure 5. Driver Enable and Disable Times ( $t_{DZL}$ ,  $t_{DLZ}$ ,  $t_{DLZ(SHDN)}$ )

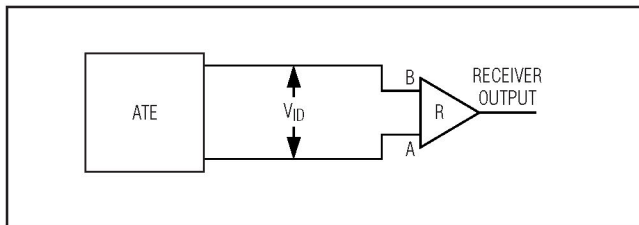

Figure 6. Receiver Propagation Delay Test Circuit

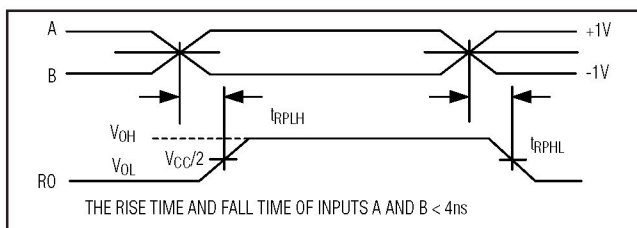

Figure 7. Receiver Propagation Delays



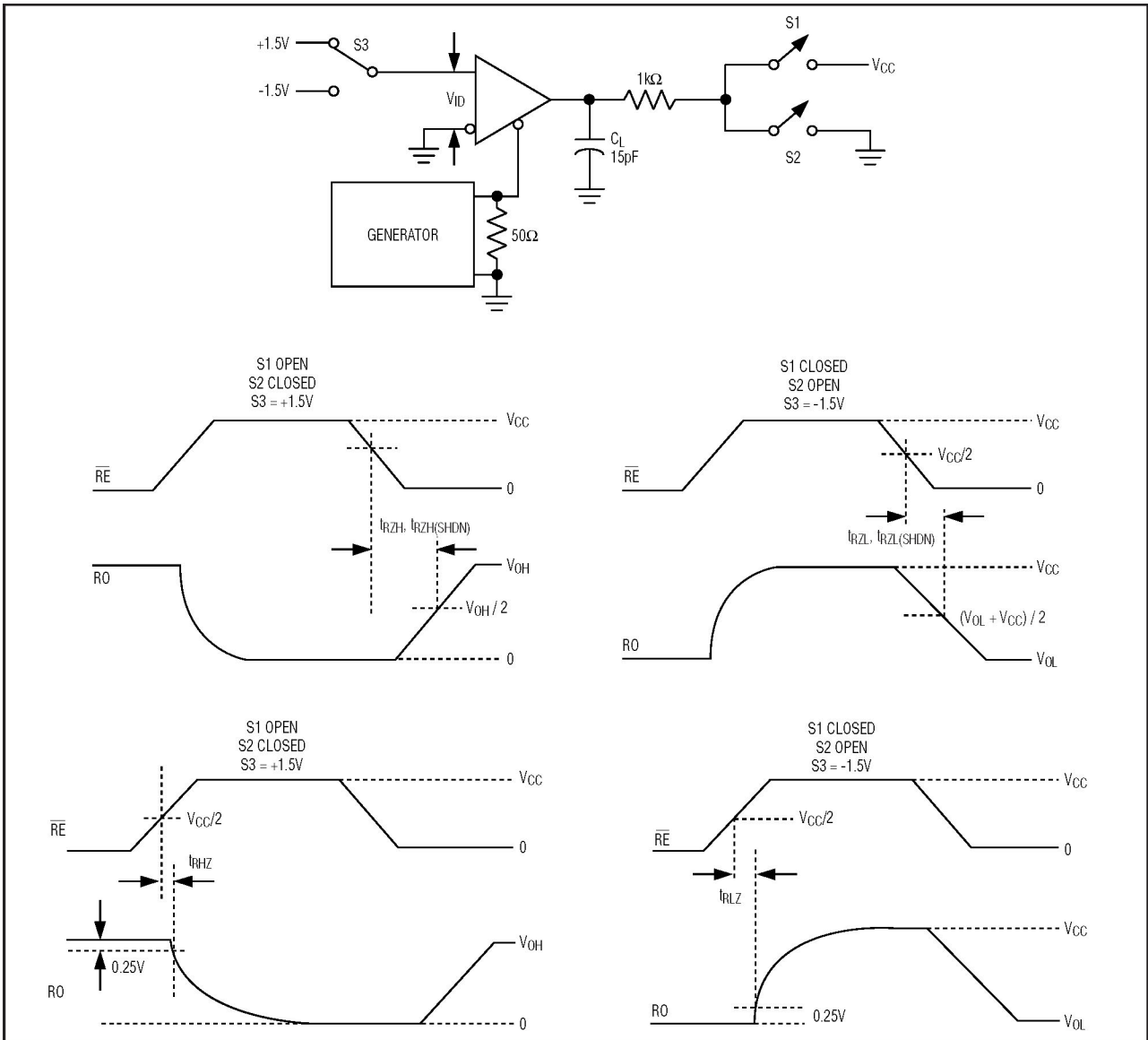
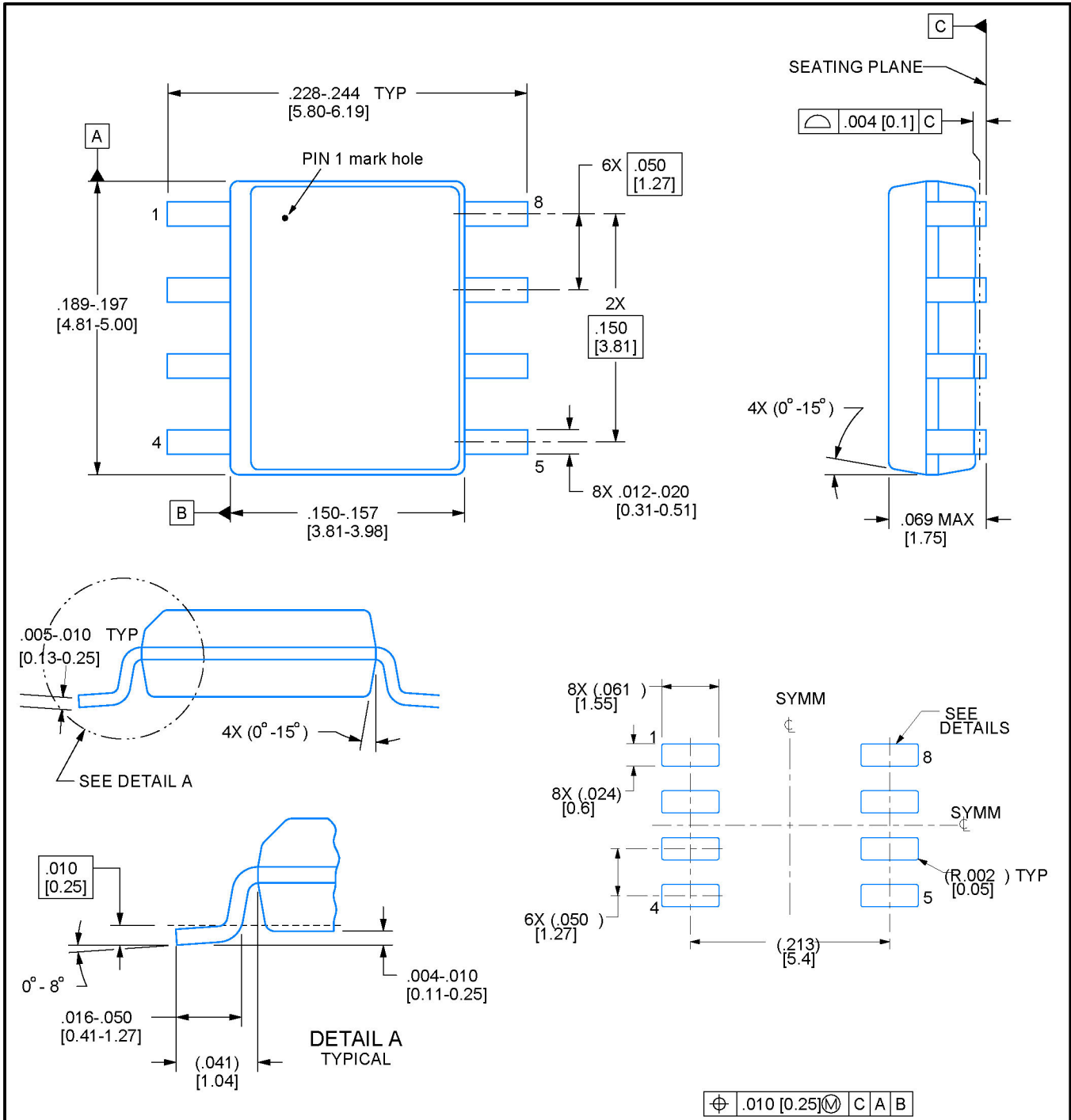

Figure 8. Receiver Enable and Disable Times



**PACKAGE OUTLINE SOIC - 8,1.75 mm max height**



NOTES: Linear dimensions are in inches [millimeters]. This dimension does not include mold flash, protrusions, or gate burrs. Mold flash, protrusions, or gate burrs shall not exceed  $.006$  [0.15] per side.