

Hex Schmitt-Trigger Inverter

DESCRIPTION

The 74HC14 is identical in pinout to the LS/ALS14. The device inputs are compatible with standard CMOS outputs; with pullup resistors, they are compatible with LS/ALSTTL outputs.

The 74HC14 is useful to “square up” slow input rise and fall times. Due to the hysteresis voltage of the Schmitt trigger, the 74HC14 finds applications in noisy environments.

FEATURES

- Outputs Directly Interface to CMOS, NMOS, and TTL
- Operating Voltage Range: 2.0 to 6.0 V
- Low Input Current: 1.0 μ A
- High Noise Immunity Characteristic of CMOS Devices
- TA = -40° to 125° C for all packages

ORDERING INFORMATION

Part Number	Package	Packing	Temperature(TA)	Package Qty
74HC14D	SOIC-14	Reel	-40°C ~ 125°C	2500
74HC14P	TSSOP-14	Reel	-40°C ~ 125°C	2500

PIN ASSIGNMENT

A1	1 ●	14	V _{CC}
Y1	2	13	A6
A2	3	12	Y6
Y2	4	11	A5
A3	5	10	Y5
Y3	6	9	A4
GND	7	8	Y4

FUNCTION TABLE

Inputs	Output
A	Y
L	H
H	L

LOGIC DIAGRAM

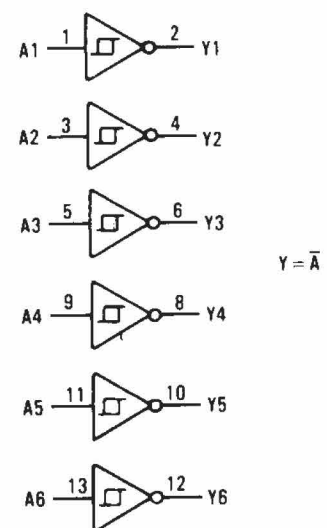

PIN 14 = V_{CC} PIN 7 = GND

MAXIMUM RATINGS

Symbol	Parameter	Value	Unit
V_{CC}	DC Supply Voltage (Referenced to GND)	-0.5 to +7.0	V
V_{IN}	DC Input Voltage (Referenced to GND)	-1.5 to $V_{CC} + 1.5$	V
V_{OUT}	DC Output Voltage (Referenced to GND)	-0.5 to $V_{CC} + 0.5$	V
I_{IN}	DC Input Current, per Pin	± 20	mA
I_{OUT}	DC Output Current, per Pin	± 25	mA
I_{CC}	DC Supply Current, V_{CC} and GND Pins	± 50	mA
P_D	Power Dissipation in Still Air, Plastic DIP** SOIC Package**	750 500	mW
Tstg	Storage Temperature	-55 to +150	°C
T_L	Lead Temperature, 1 mm from Case for 10 Seconds (Plastic DIP or SOIC Package)	260	°C

*Maximum Ratings are those values beyond which damage to the device may occur. Functional operation should be restricted to the Recommended Operating Conditions.

**Derating - Plastic DIP: - 10 mW/°C from 65° to 125°C
SOIC Package: - 7 mW/°C from 65° to 125°C

RECOMMENDED OPERATING CONDITIONS

Symbol	Parameter	Min	Max	Unit
V_{CC}	DC Supply Voltage (Referenced to GND)	2.0	6.0	V
V_{IN}, V_{OUT}	DC Input Voltage, Output Voltage (Referenced to GND)	0	V_{CC}	V
T_A	Operating Temperature, All Package Types	-40	+125	°C
t_r, t_f	Input Rise and Fall Time (Figure 1)	-	No Limit*	ns

* When $V_{IN} \approx 50\% V_{CC}$, $I_{CC} > 1mA$

This device contains protection circuitry to guard against damage due to high static voltages or electric fields. However, precautions must be taken to avoid applications of any voltage higher than maximum rated voltages to this high-impedance circuit. For proper operation, V_{IN} and V_{OUT} should be constrained to the range $GND \leq (V_{IN} \text{ or } V_{OUT}) \leq V_{CC}$.

Unused inputs must always be tied to an appropriate logic voltage level (e.g., either GND or V_{CC}). Unused outputs must be left open.

DC ELECTRICAL CHARACTERISTICS (Voltages Referenced to GND)

Symbol	Parameter	Test Conditions	V _{CC} V	Guaranteed Limit			Unit
				25 °C to -55°C	≤85 °C	≤125 °C	
V _T +max	Maximum Positive-Going Input Threshold Voltage	V _{OUT} =0.1 V I _{OUT} ≤ 20 μA	2.0	1.5	1.5	1.5	V
			4.5	3.15	3.15	3.15	
			6.0	4.2	4.2	4.2	
V _T +min	Minimum Positive-Going Input Threshold Voltage	V _{OUT} =0.1 V I _{OUT} ≤ 20 μA	2.0	1.0	0.95	0.95	V
			4.5	2.3	2.25	2.25	
			6.0	3.0	2.95	2.95	
V _T -max	Maximum Negative-Going Input Threshold Voltage	V _{OUT} =V _{CC} -0.1 V I _{OUT} ≤ 20 μA	2.0	0.9	0.95	0.95	V
			4.5	2.0	2.05	2.05	
			6.0	2.6	2.65	2.65	
V _T -min	Minimum Negative-Going Input Threshold Voltage	V _{OUT} =V _{CC} -0.1 V I _{OUT} ≤ 20 μA	2.0	0.3	0.3	0.3	V
			4.5	0.9	0.9	0.9	
			6.0	1.2	1.2	1.2	
V _H max *	Maximum Hysteresis Voltage	V _{OUT} =0.1 V or V _{CC} -0.1 V I _{OUT} ≤ 20 μA	2.0	1.2	1.2	1.2	V
			4.5	2.25	2.25	2.25	
			6.0	3.0	3.0	3.0	
V _H min *	Minimum Hysteresis Voltage	V _{OUT} =0.1 V or V _{CC} -0.1 V I _{OUT} ≤ 20 μA	2.0	0.2	0.2	0.2	V
			4.5	0.4	0.4	0.4	
			6.5	0.5	0.5	0.5	
V _{OH}	Minimum High-Level Output Voltage	V _{IN} ≤V _T -min I _{OUT} ≤ 20 μA	2.0	1.9	1.9	1.9	V
			4.5	4.4	4.4	4.4	
			6.0	5.9	5.9	5.9	
V _{OL}	Maximum Low-Level Output Voltage	V _{IN} ≥V _T +max I _{OUT} ≤ 20 μA	2.0	0.1	0.1	0.1	V
			4.5	0.1	0.1	0.1	
			6.0	0.1	0.1	0.1	
V _{OL}	Maximum Low-Level Output Voltage	V _{IN} ≥V _T +max I _{OUT} ≤ 4mA I _{OUT} ≤ 5.2mA	4.5	0.26	0.33	0.4	V
			6.0	0.26	0.33	0.4	
I _{IN}	Maximum Input Leakage Current	V _{IN} =V _{CC} or GND	6.0	±0.1	±1.0	±1.0	μA
I _{CC}	Maximum Quiescent Supply Current (per Package)	V _{IN} =V _{CC} or GND I _{OUT} =0μA	6.0	1.0	10	40	μA

* V_Hmin>(V_T+min)-(V_T-max); V_Hmax=(V_T+max)-(V_T-min)

AC ELECTRICAL CHARACTERISTICS ($C_L=50\text{pF}$, $t_r=t_f=6.0\text{ ns}$)

Symbol	Parameter	V_{CC} V	Guaranteed Limit			Unit
			25 °C to -55°C	≤85°C	≤125°C	
t_{PLH} , t_{PHL}	Maximum Propagation Delay, Input A to Output Y (Figures 1 and 2)	2.0 4.5 6.0	95 19 16	120 24 20	145 29 25	ns
t_{TLH} , t_{THL}	Maximum Output Transition Time, Any Output (Figures 1 and 2)	2.0 4.5 6.0	75 15 13	95 19 16	110 22 19	ns
C_{IN}	Maximum Input Capacitance	-	10	10	10	pF
C_{PD}	Power Dissipation Capacitance (Per Inverter)	$T_A=25^\circ\text{C}, V_{CC}=5.0\text{ V}$			pF	
	Used to determine the no-load dynamic power consumption: $P_D=C_{PD}V_{CC}^2f+I_{CC}V_{CC}$	22				

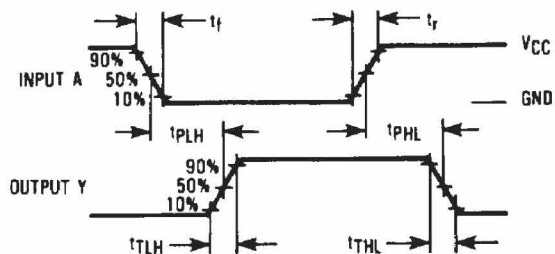
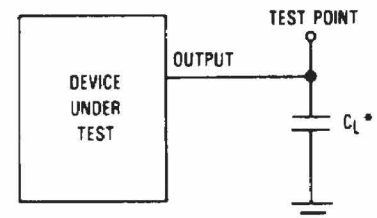
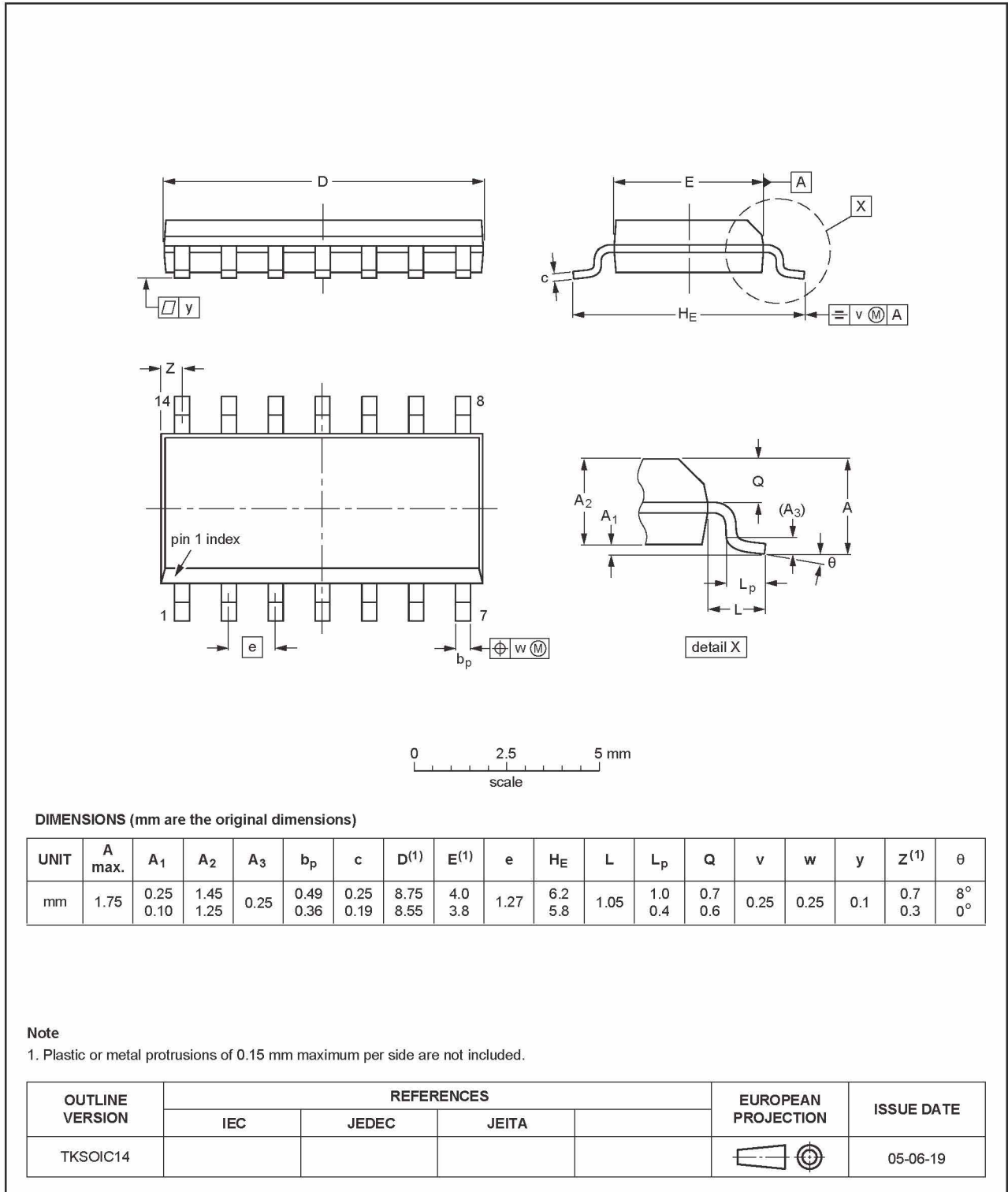

Figure 1. Switching Waveforms

*Includes all probe and jig capacitance.

Figure 2. Test Circuit

Package diagram

SOIC14: plastic small outline package; 14 leads; body width 3.9 mm

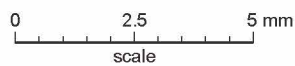
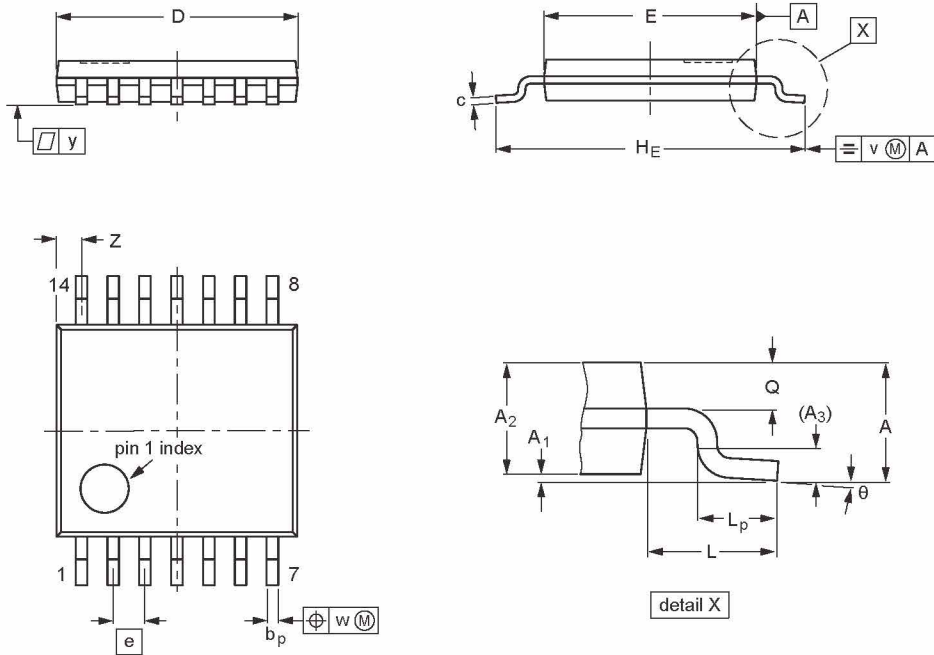

TSSOP14: plastic thin shrink small outline package; 14 leads; body width 4.4 mm

DIMENSIONS (mm are the original dimensions)

UNIT	A max.	A ₁	A ₂	A ₃	b _p	c	D ⁽¹⁾	E ⁽²⁾	e	H _E	L	L _p	Q	v	w	y	Z ⁽¹⁾	θ
mm	1.1	0.15 0.05	0.95 0.80	0.25	0.30 0.19	0.2 0.1	5.1 4.9	4.5 4.3	0.65	6.6 6.2	1	0.75 0.50	0.4 0.3	0.2	0.13	0.1	0.72 0.38	8° 0°

Notes

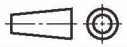
1. Plastic or metal protrusions of 0.15 mm maximum per side are not included.
2. Plastic interlead protrusions of 0.25 mm maximum per side are not included.

OUTLINE VERSION	REFERENCES			EUROPEAN PROJECTION	ISSUE DATE
	IEC	JEDEC	JEITA		
TKTSSOP14					05-06-19